

HPGM 375 - HPGM 4500

www.wiggert.com

Mixer	HPGM	375	500	750	1125	1500	1875	2250-1	3000	3750-1	4500
Dry filling capacity	L	375	500	750	1125	1500	1875	2250	3000	3750	4500
Output per batch, compacted fresh concrete	L	250	333	500	750	1000	1250	1500	2000	2500	3000
Mixer drive motor ¹⁾	kW	9,0	11	18,5	30	45	55	75	90	110	132
Hydraulic drive motor	kW	2,2	2,2	2,2	2,2	2,2	2,2	2,2	2,2	2,2	2,2
Mixing stars	Pcs.	1	1	1	1	2	2	2	3	3	3
Mixing shovels / mixing star	Pcs.	2	2	2	3	2	2	2	3	3	3
Discharge aid	Pcs.			1	1	2	2	2	2	2	2
Side scraper	Pcs.	1	1	1	1	1	1	1	1	1	1
Speed of rotor ²⁾ / (with 60 Hz)	Rpm	17,2/(17,6)	14,6/(15,2)	13,2/(13,2)	12,3/(12,3)	10,8/(10,9)	11,7/(11,8)	11,8/(12)	10,4/(11)	9,2/(11)	10,2/(10,1)
Mixing star rotation ²⁾ / (with 60 Hz)	Rpm	61,9/(63,4)	52,6/(54,7)	50,9/(50,9)	43,9/(43,9)	36/(36,4)	39,1/(39,2)	39,4/(39,8)	37,7/(39,9)	37,7/(39,9)	42,1/(41,3)
Water connection	Inch	1 ½	1 ½	1 ½	2	2	2	2	3	3	3
Weight of mixer	kg	1600	1960	2450	3800	5050	5250	5950	7650	7920	9580

Skip Hoists	HPGM	375	500	750	1125	1500	1875	2250-1	3000	3750	4500
Dry filling capacity	L	375	500	750	1125	1500	1875	2250	3000	3750	4500
Max. filling weight	kg	500	750	1000	1500	2000	2500	3000	4000	5000	6000
Hoist drive motor	kW	4	5,5	7,5	11	15	15	18,5	22	30	45
Speed of hoist up/down ³⁾	m/sec.	0,4	0,4	0,4	0,4	0,4	0,4	0,4	0,4	0,4	0,34
Diam. of hoisting cable	mm	12	12	12	12	12	12	16	18	18	15
Weight of skip hoist	kg	900	950	1100	1400	1700	1750	1800	2500	2700	upon request

	HPGM	375	500	750	1125	1500	1875	2250-1	3000	3750-1	4500
A	1300	1500	1800	2270	2500	2500	2750	2880	3300	3300	
B	1390	1590	1900	2370	2600	2600	2850	3000	3420	3420	
C	600	650	750	750	800	800	800	1000	1000	1000	
D	298	298	276	272	320	320	320	330	300	330	
E	223	325	354	551	692	770	770	1036	1057	1057	
F	375	481	610	665	697	697	889	889	1153	1153	
G	585	585	860	1053	1400	1400	1400	1640	1840	1840	
H	267	320	358	398	450	450	546	546	620	620	
I	460	590	770	900	1020	1020	1140	1100	1300		
J	770	870	1020	1255	1370	1370	1495	1560	1770	1770	
K	120	120	120	120	120	120	120	120	120	120	
L	1136	1290	1470	1880	2000	2000	2120	2220	2460		
M	56	56	56	60	60	60	60	60	60	60	
N	2405	2895	2900	3613	3613	3613	3927	4950	4950		
O	1546	1804	2085	2313	2584	2584	2854	3335	3590	3620	
P	140	140	140	180	180	180	180	200	200		
Q	70	70	70	74	74	74	74	74	74	74	
R	944	944	944	1149	1149	1344	1554	1640	1640		
S	2100	2250	2500	2950	3100	3270	3450	3800	3800		
T	944	944	944	1149	1149	1149	1454	1814	1814		
U	-	100	250	150	300	470	300	100	300		
V	1250	1390	1600	1880	2130	2130	2255	2410	2720	2720	
W	480	520	580	625	760	760	760	850	950	950	
X	140	140	140	150	150	150	150	200	200		
Y	60	60	60	70	70	70	70	75	75		
Z	1300	1300	1300	1700	1700	1700	1700	2330	2330		
a	1100	1100	1100	1500	1500	1500	1500	2000	2000		
b	1100	1100	1100	1348	1348	1348	1700	1828	1828		
c	1100	1038	951	1257	1171	1298	1638	1766	1651		

All dimensions in mm
(25.4 mm = 1 inch, 1 cu.yd. = 765 ltr., 1 lb = 0,454 kg)
Modifications reserved

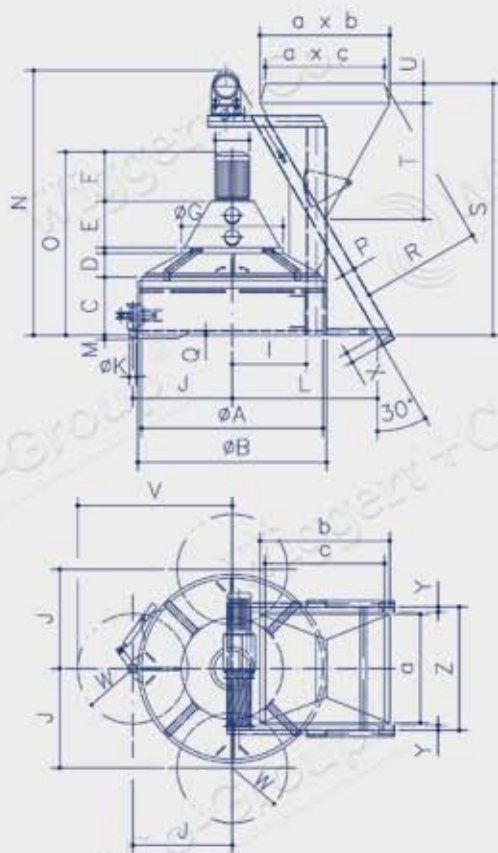

Flexible equipment program offers profitable and superior concrete production

The Program

www.wiggert.com



Proven on construction sites and in the ready-mix industry: CENTROMAT plants with boom scraper MobilMat plants with row-type bins or round silo.



Plants for the concrete products industry – designed to meet your requirements.



Customized plants with 1, 2 or more mixers for various applications.



PCS – Programmable Control Systems – put you in total control.

Concrete transport systems with bottom discharge or roll-over bucket.



Planetary Countercurrent Mixer



Twin Shaft Mixer

ADVANCED CONCRETE TECHNOLOGIES
WE ADD PROFITABILITY TO THE MIX.
American Division of Wiggert+Co. and Würschum
Member of:

300 Portsmouth Avenue
Greenland, NH 03840
phone: 603.431.5661 fax: 603.431.5547
info@concretebiz.com
www.concretebiz.com



CENTROMAT Plants
Storage of aggregates in star bins with boom scraper
20 - 105 m³/h

MobilMat Plants
Storage of aggregates in row-type bins or round silo
15 - 180 m³/h

EconoMat Plants
The alternative – offering the most for the least costs

SmartMix Plants
The smart solution for the small concrete producer

Twin Mixer Plants
customized to your special needs

Planetary Countercurrent Mixers
375 - 4500 l

Twin Shaft Mixers
1875 - 6750 l

Concrete Transport Systems

Boom Scrapers

Controls



HPGM Planetary Countercurrent Mixer



HPGM 375

HPGM 500

HPGM 750

HPGM 1125

HPGM 1500

HPGM 1875

HPGM 2250

HPGM 3000

HPGM 3750

HPGM 4500

Wiggert + Co.
KABAG
Advanced Mixing Technology



www.wiggert.com

Modifications reserved - HPGM 09/08